

MODULO ESCRIVANINHA ES1500

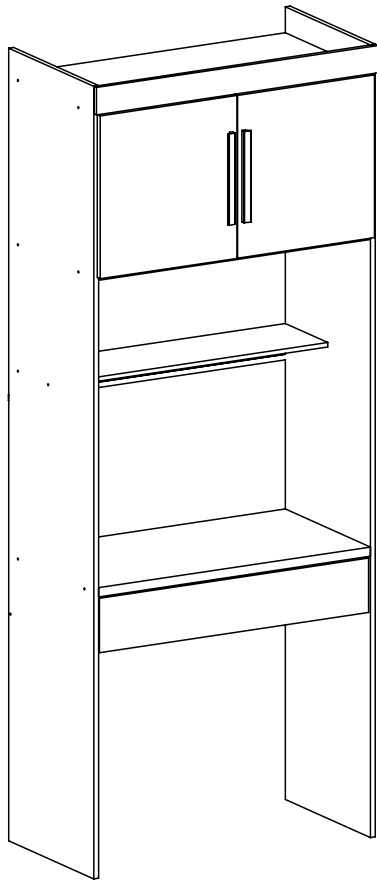

Siga Móveis Rodial



Parabéns

Você acabou de receber um produto exclusivo da Móveis Rodial!

Informações Úteis

É recomendada a prévia leitura de toda a instrução de montagem e conferência das peças e componentes antes de iniciar a montagem do produto.

A montagem do produto deverá ser feita em superfície limpa e plana. Aconselhamos utilizar a embalagem do produto para forrar o chão a fim de não danificar o produto.

Durante a montagem evite batidas e contato com objetos cortantes. Observar as cargas máximas suportado pelo produto.

Limpeza

Retire o pó com uma flanela seca e depois utilize um pano macio umedecido com água.

Não utilizar produtos químicos e abrasivos

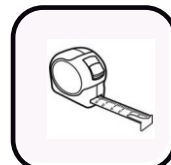
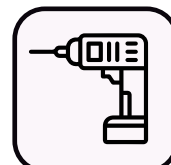

Nº DA PEÇA	DESCRIÇÃO	QTD	CÓD. BRANCO	CÓD. CINAMOMO	CÓD. CINAMOMO OFF WHITE	CÓD. CINAMOMO CAPPUCCINO
1	CHAPÉU 830X450X12	2	30041	30375	30375	30375
2	CHAPÉU 830X225X12	2	35074	34687	34687	34687
3	COSTA 856X431X3	2	35140	34681	34681	34681
4	COSTA 856X454X3	1	35141	34682	34682	34682
5	ENCABEÇAMENTO 860X75X15	1	32989	32768	32768	32768
6	FRENTE GAVETA 822X149X15	1	35098	34683	34683	34683
7	FUNDO DE GAVETA 804X363X3	1	34865	34866	34866	30866
8	LATERAL 2170X450X15 DIR	1	35106	34684	34684	34684
9	LATERAL 2170X450X15 ESQ	1	35107	34685	34685	34685
10	LATERAL DE GAVETA 360X90X12	2	28405	30352	30352	30352
11	PORTA 446X418X15	2	35117	34797	34686	34795
12	TAMPO 830X450X25	1	35130	34688	34688	34688
13	TRASEIRO DE GAVETA 782X90X12	1	30049	30382	30382	30382
14	TRAVESSA 830X150X15	1	35134	34689	34689	34689

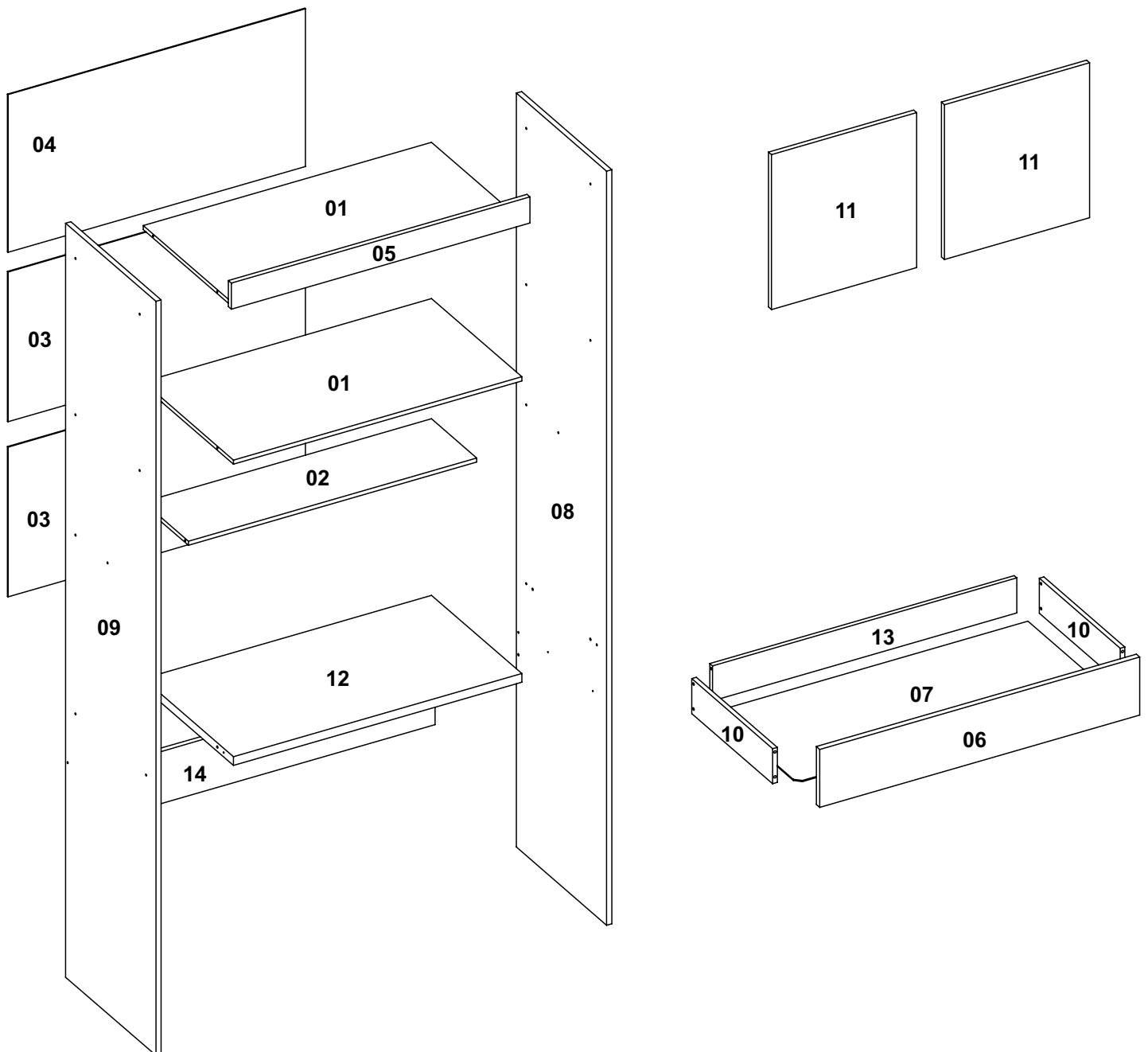

Lista de Ferragens

Parafuso 4,0x40 - Cod.3983

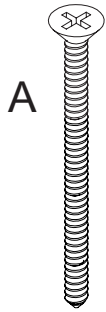

A

x18

Parafuso 3,5x12 Cód.3385



B

x40

Porca plástica Cód.3991



C

x14

Cavilha 6x30 Cód.3881



D

x14

Prego 10x10 Cód.33412



E

x90

12x12-Cod 3876



F

x15

856mm

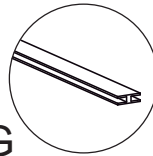

G

x1

Sapata simples Cód.31330

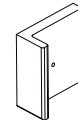

H

x4

Cod 3882

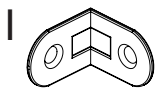

I

x5

3,5x25-cod 7182

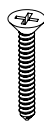

J

x6

192MM



K

x2

3,5x25-Cod 3870

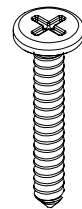

L

x4

Cod 3384

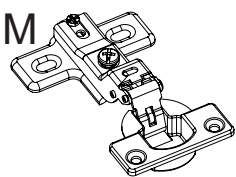

M

x4

Cod 3872

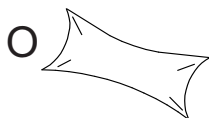

O

x1

Cod 3877

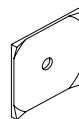

P

x10

300MM-Cod 29265

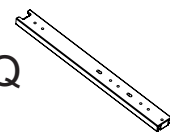

Q

x1

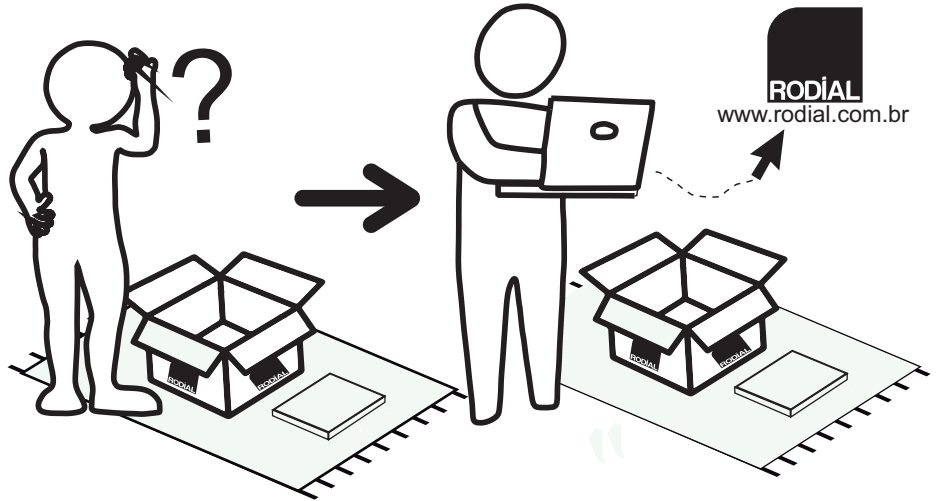
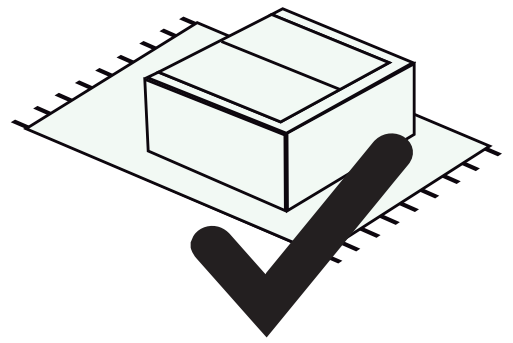
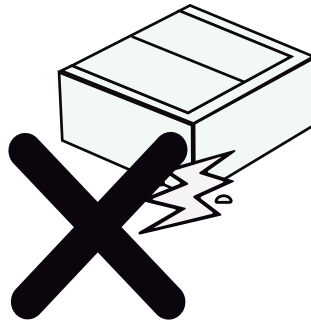
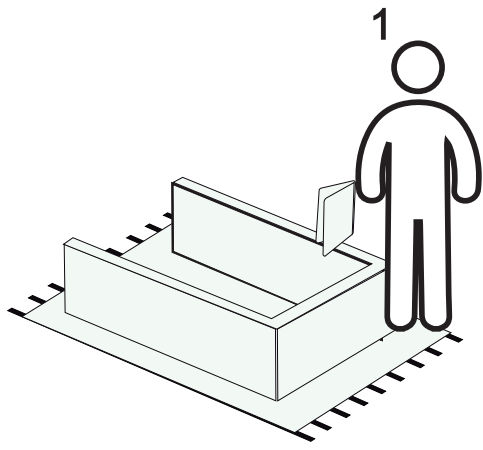

1

Pressione a trava para
desmontar a corrediça
para ser usada na montagem
da gaveta.

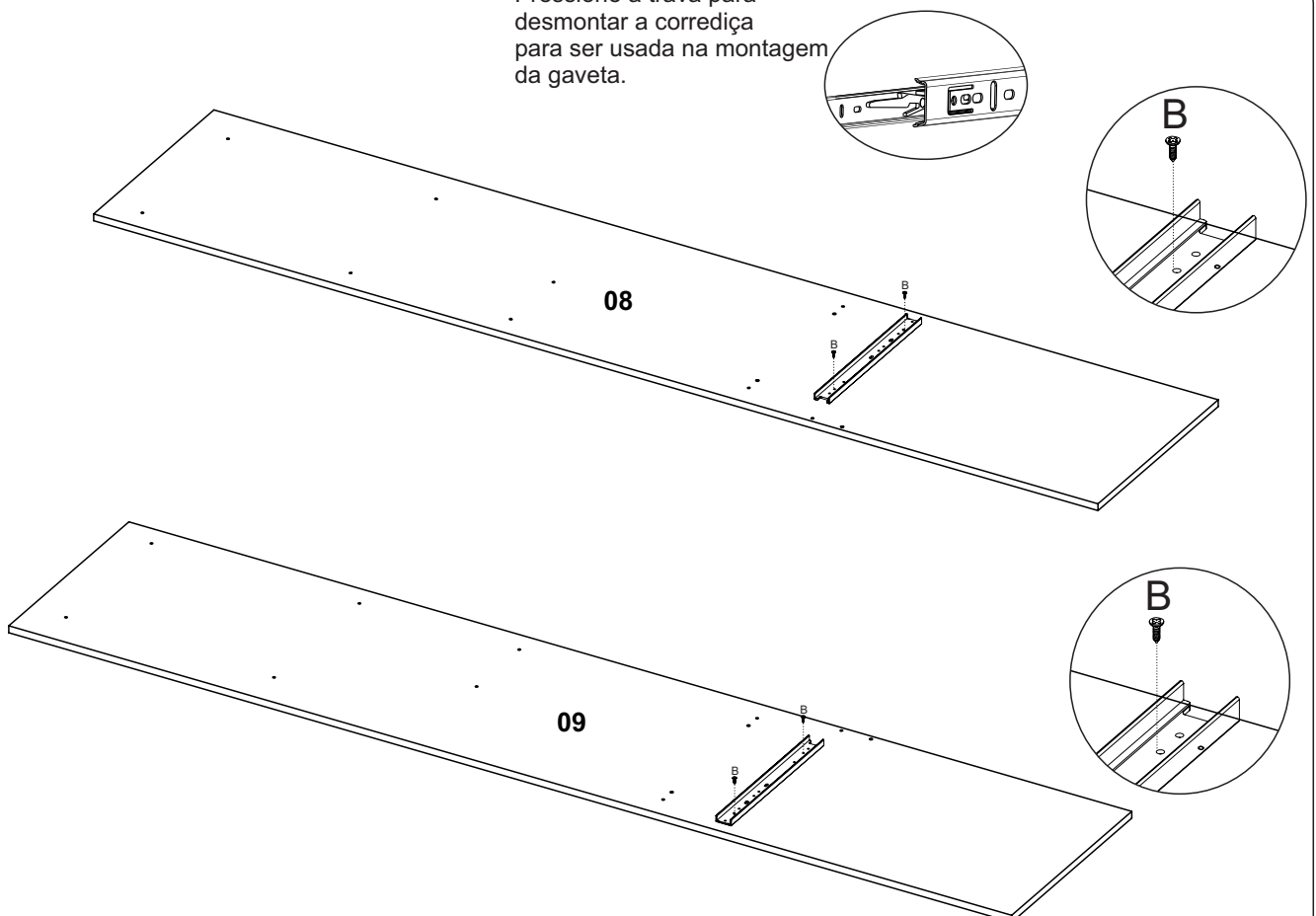

2

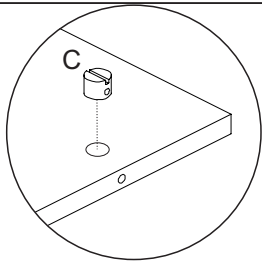

2X

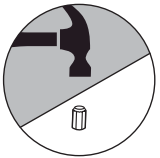
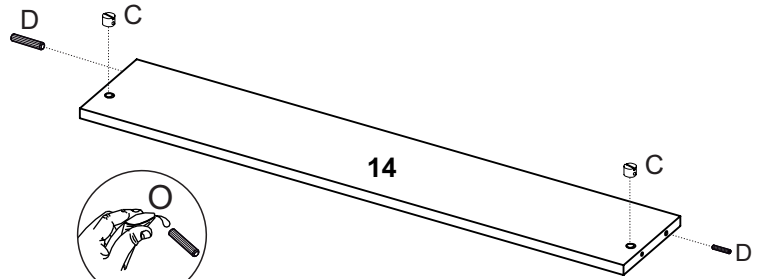
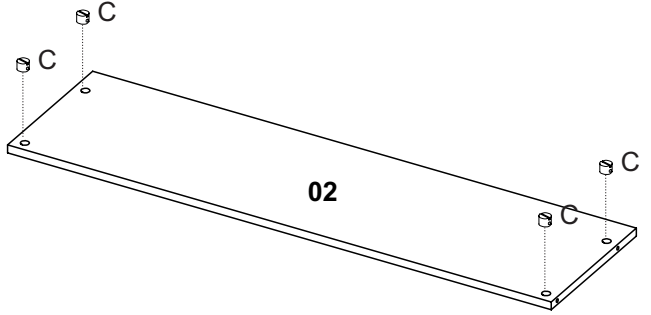
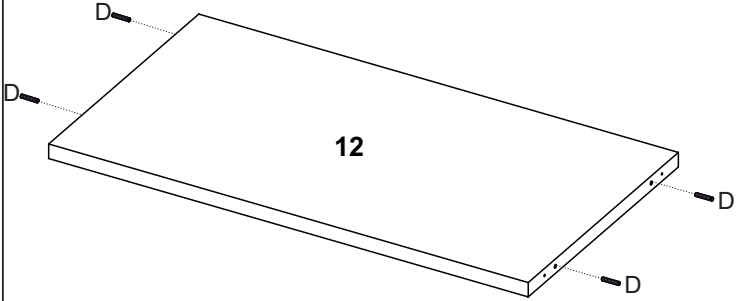
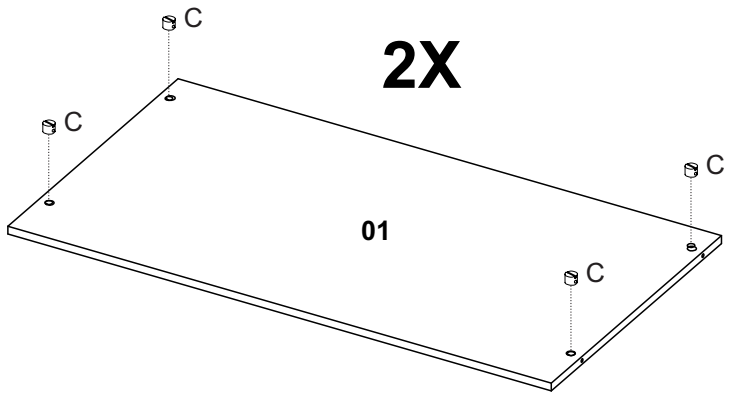

3

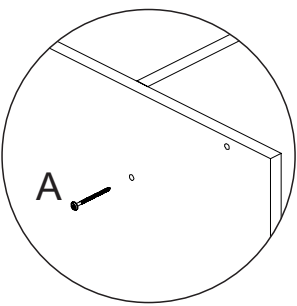
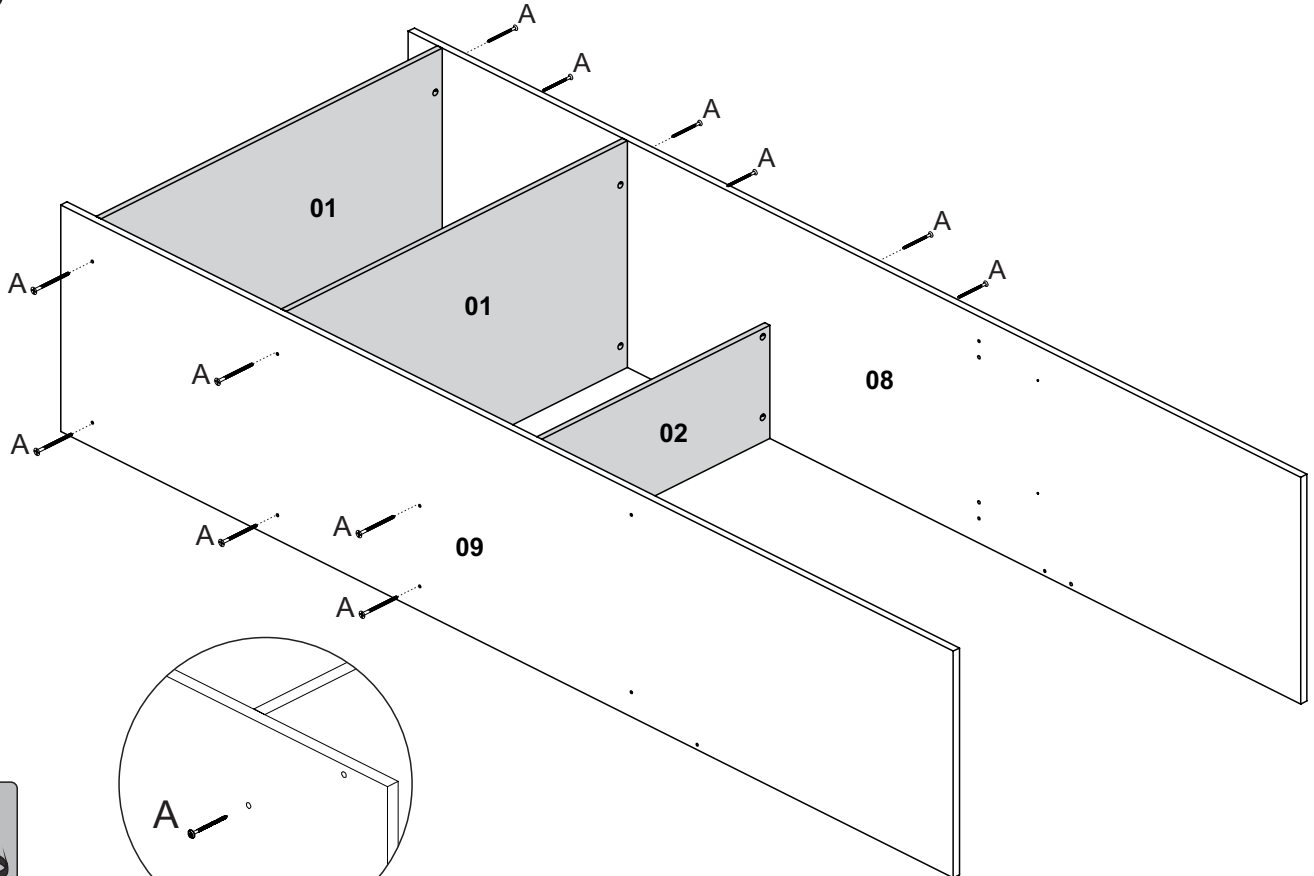

4

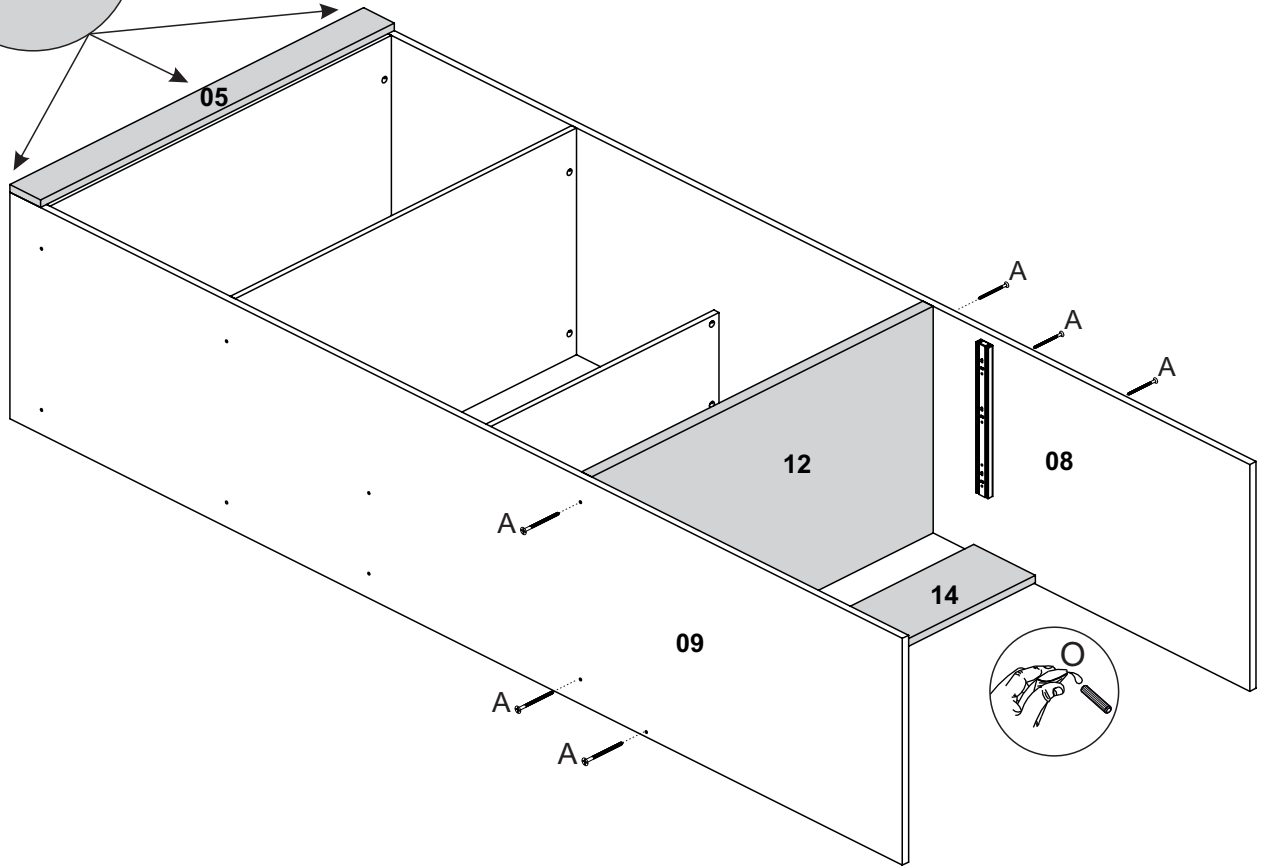
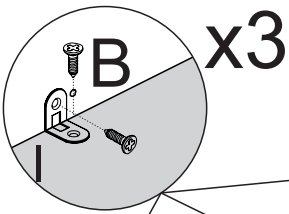

5

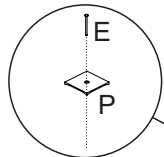
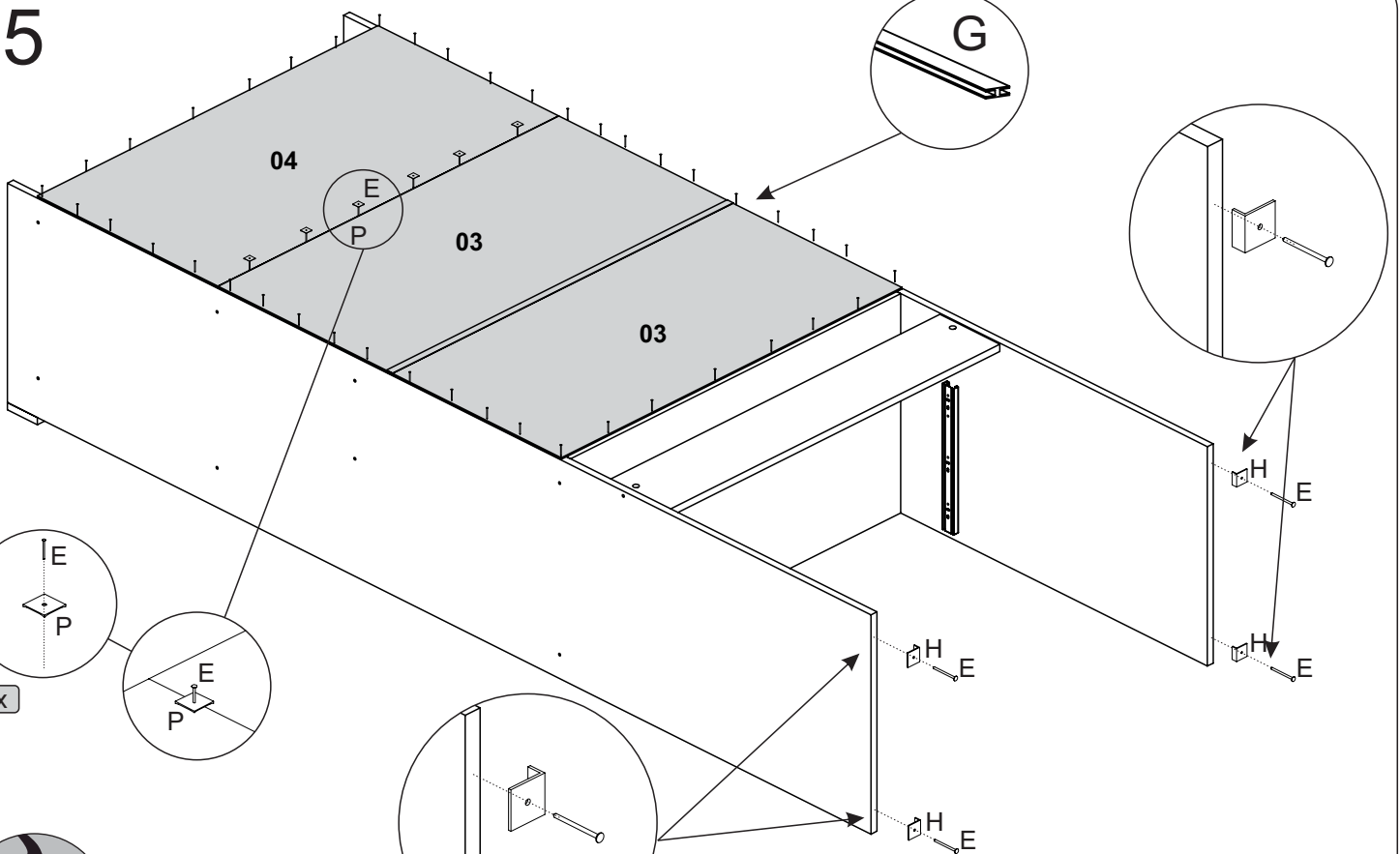
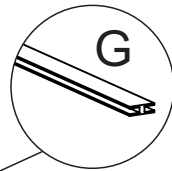

10x

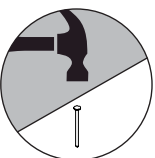
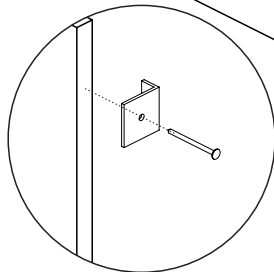
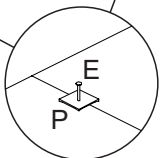

6

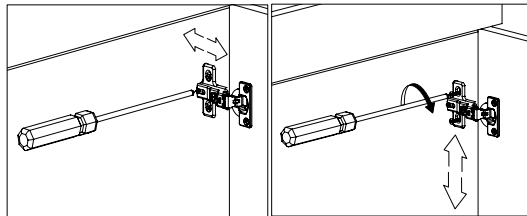
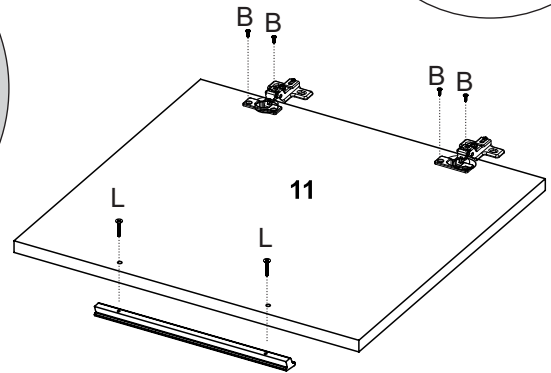
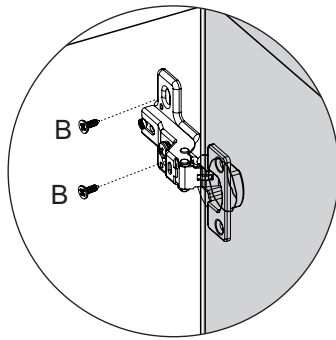
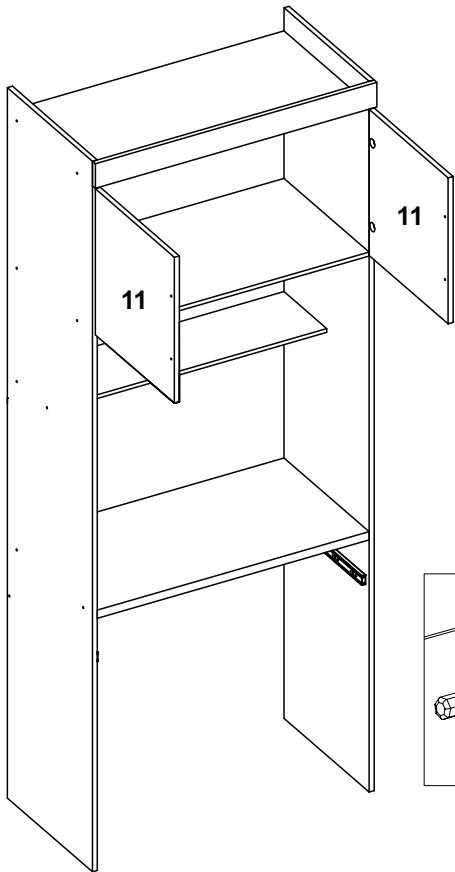
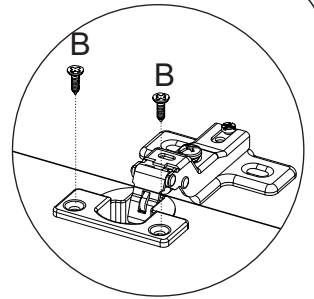
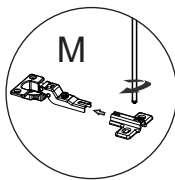

Regulagem da Dobradiça

7

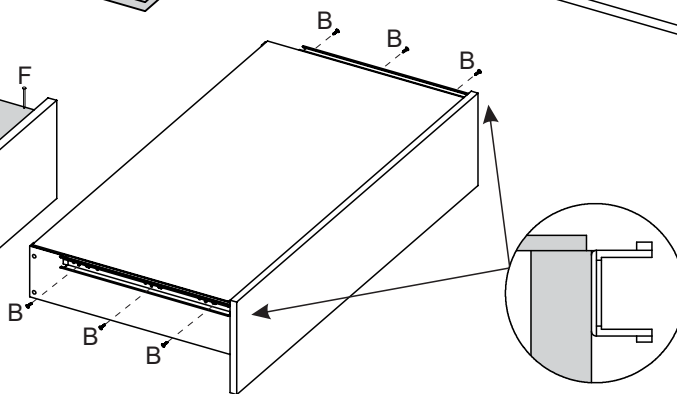
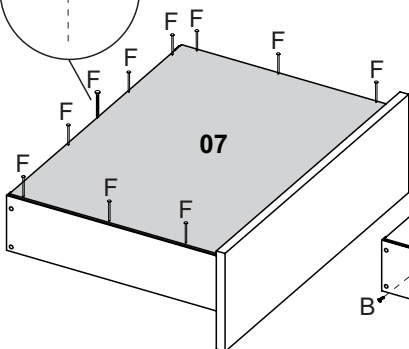
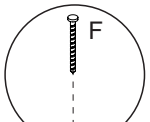
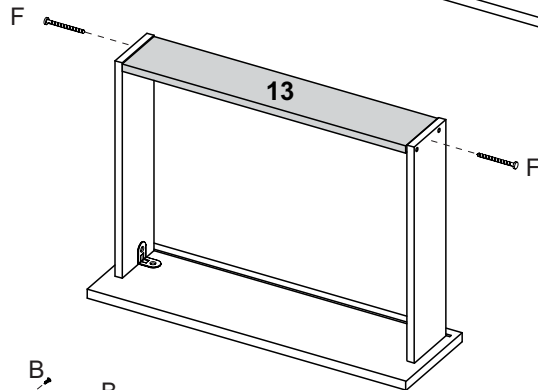
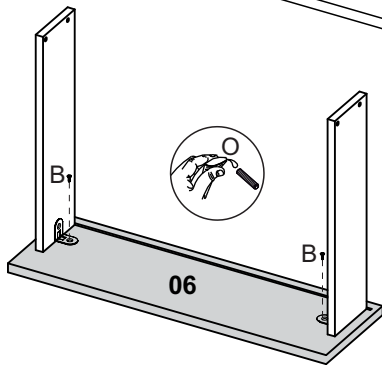
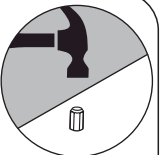
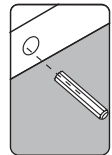
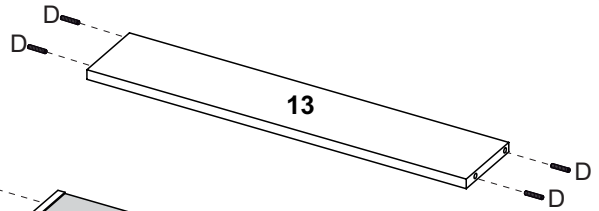
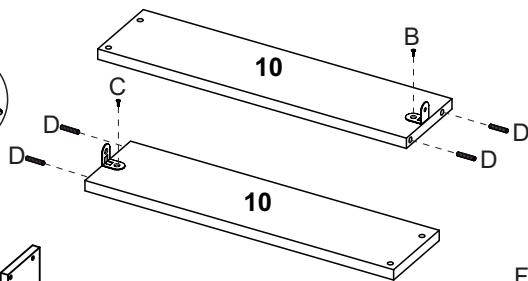

8

União com Outros Modulos(Opcional)

